

Low Distortion Oscillator Series 3

Technical Instructions Installation and Advanced Maintenance

1. GENERAL
2. CONTROLS, FUNCTIONS AND FACILITIES
 - 2.1 Attenuator output source resistance
 - 2.2 Floating output
 - 2.3 'Oscillator off' facility
3. CALIBRATION
 - 3.1 Frequency adjustment
 - 3.2 Output monitoring meter, f.s.d. adjustment
 - 3.3 Power supply voltage adjustment
4. MAINTENANCE
 - 4.1 Replacement of components
 - 4.2 Distortion consequent upon component replacement
5. GUARANTEE
 - 5.1 Home
 - 5.2 Overseas

3. CALIBRATION

3.1 Frequency adjustment

The frequency dial is set on the spindle of the potentiometer to read the correct frequency on the 1–10 kHz range at 3 kHz. The calibration accuracy at this setting of the dial on the other bands at 30 Hz, 300 Hz and 30 kHz is within 5%, typically 2% to 3%. Similarly the inaccuracies at the extremes of the dial marked 10 and 100 are also within 5% and typically 2% to 3% except at high frequencies between 60 and 100 kHz.

3.2 Output monitoring meter

The meter is a simple rectifier type and responds to the average value of the waveform calibrated in r.m.s. reading.

Sine wave adjustment P4 On sine wave output P4 is adjusted to read correct f.s.d. at 1.0 volt input against a reference voltmeter.

Square wave adjustment P5 P5 is adjusted for r.m.s. reading with a dynamometer or other true r.m.s. responding meter with a square wave input. If an average responding meter, calibrated for r.m.s. reading on a sine wave is used it should read 1.0 V when the monitor meter is adjusted to read 0.9 V.

3.3 Power supply voltage

Pre-set potentiometer P2 is used to set the –15 V supply rail which automatically sets to +60 V rail also. P3 adjusts the +15 V rail.

4. MAINTENANCE

4.1 Replacement of modules or components

The schematic diagram giving component part details shows the wiring of the instrument outside the printed circuit board modules. Component part details are shown on the individual circuit diagrams of the modules. Physical layout diagrams of the complete instrument provide identification of modules. Printed circuit board modules are fitted with connectors to facilitate easy replacement.

For replacement and easy repair printed circuit board layout diagrams show copper circuitry in relation to the components. The module terminations are numbered and colour coded to ensure correct lead connection after board replacement.

The amplitude control module is incorporated in an epoxy resin housing and is unrepairable.

4.2 Distortion consequent upon component replacement

In order to obtain the desired very low distortion characteristics of the LDO3 selection of component parts is necessary in the manufacture of the instrument. If a failure occurs it is advantageous to replace a complete module with a factory tested item rather than replace a component part. However, as this may not always be practicable the following notes are included.

A specification requirement for the LDO3 is 0.002% total harmonic distortion in the middle audio frequency band but is typically less than 0.001%. With selection of components some oscillators have a distortion output which cannot be detected below the noise in total harmonic distortion measuring apparatus. (Less than 0.0005%.) Distortion may be introduced by the following components:

1. GENERAL

The instrument leaves the factory set for operation on a 240 V supply. Do not switch on until the voltage selector on the rear chassis panel has been adjusted to the correct operating mains voltage.

The sales leaflet A51 Jan. 75 describes the general principles of design of the instrument, facilities provided, and specification details.

2. CONTROLS, FUNCTIONS AND FACILITIES

2.1 Output source resistance

The standard model LDO3 is supplied with either 600 ohm or 150 ohm attenuators, as required.

2.2 Floating output

The LDO3B includes an output amplifier driving a transformer producing a floating isolated output terminated by a 600 ohm step attenuator. The 0–20 dB attenuator is interposed between the oscillator amplifier and the output amplifier. The output source resistance of the attenuator therefore remains constant at 600 ohms regardless of the setting of the 0–20 dB attenuator. A control is provided on the front panel which switches the output from floating to unbalanced. The schematic diagram illustrates the circuit details applicable to both instruments.

2.3 'Oscillator off' facility

In the middle audio band the distortion of the standard model LDO is lower than the noise of conventional distortion measuring equipment. The 'oscillator off' switch inhibits oscillation in the instrument leaving the circuit conditions unchanged. If the rejected output from the distortion measuring equipment is displayed on an oscilloscope the contribution of hum and noise in the measuring set up can thus be determined.

Fig. 2 Layout. Original design. Plan view

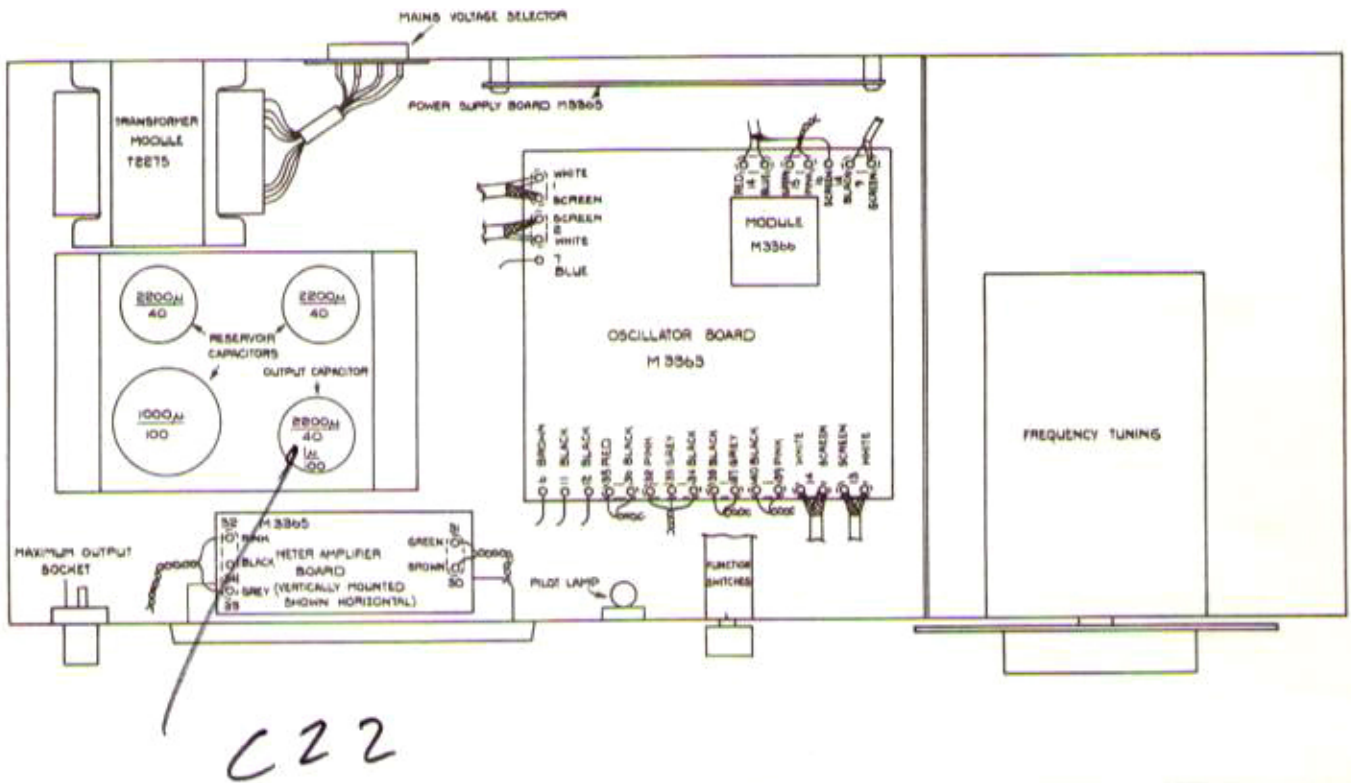

Fig. 2b Layout. Modified design. Plan view

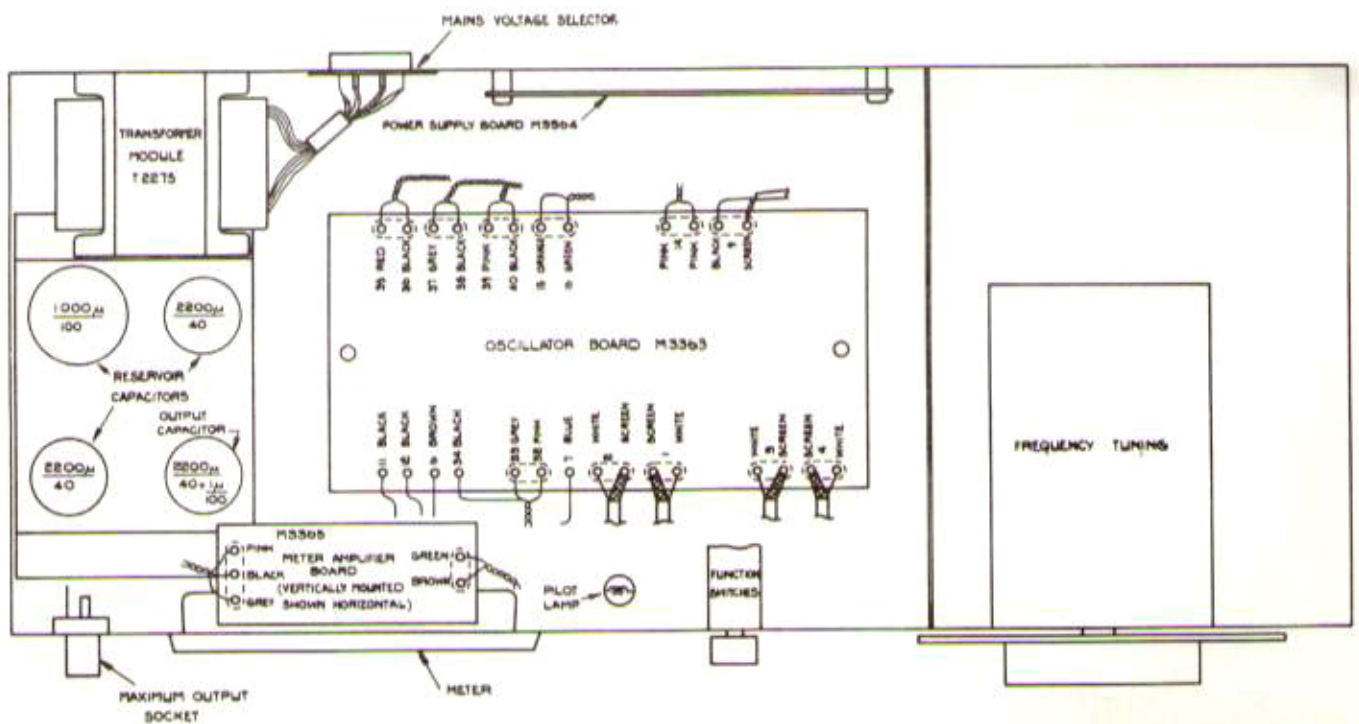

Fig. 3a Layout. Underside

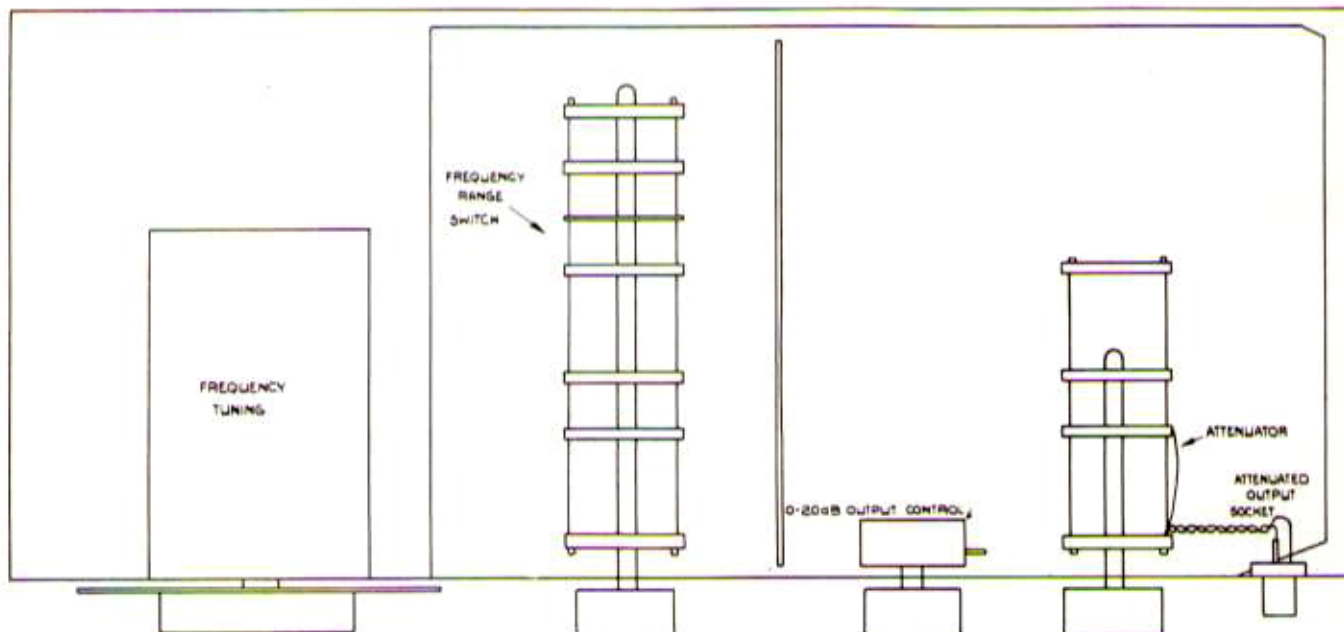

Fig. 3b Layout. Underside (Floating output model)

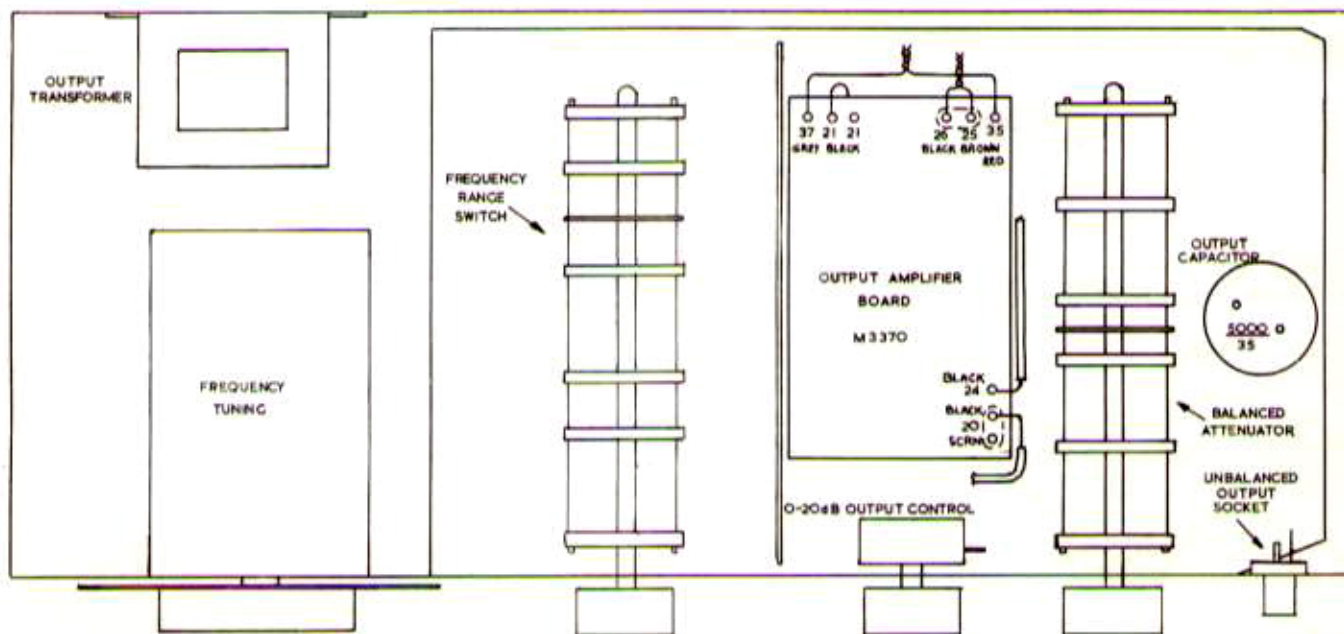

Fig. 4 Layout. Rear panel inside view

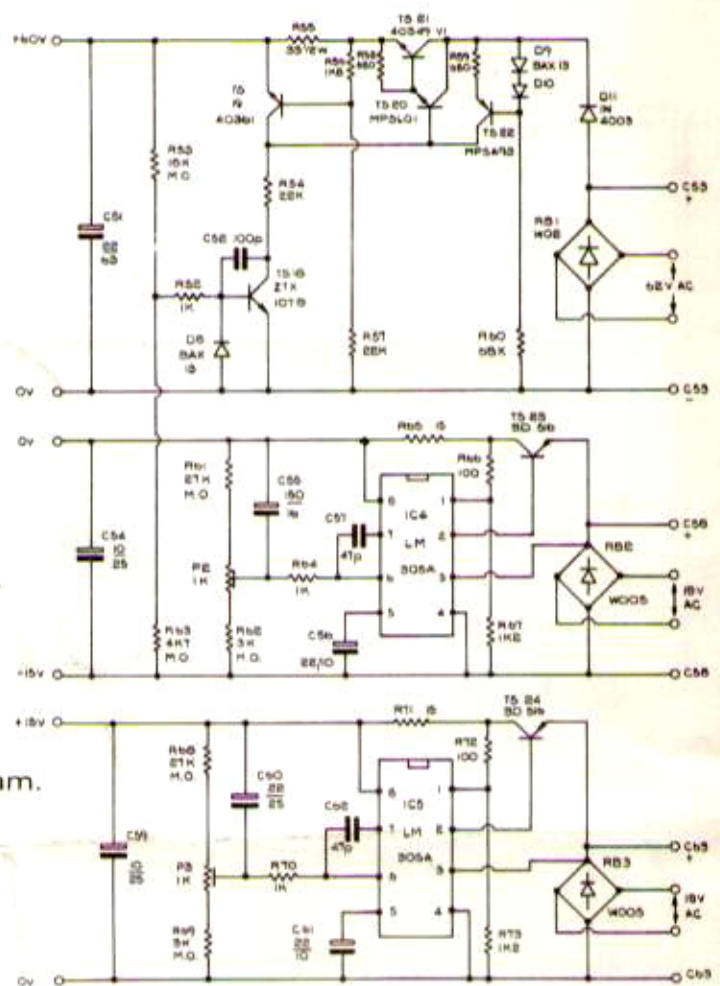
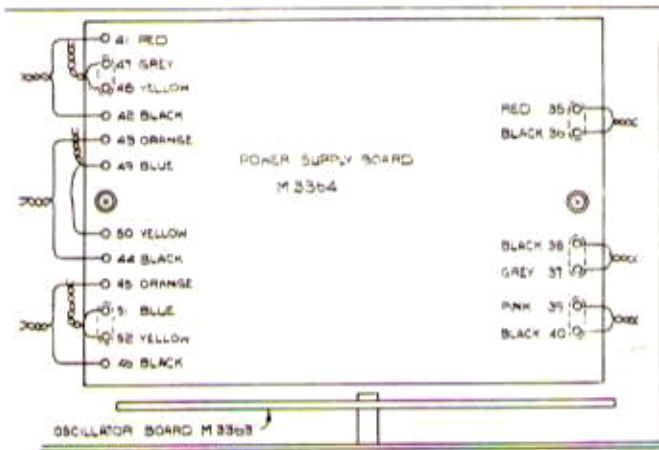

Fig. 5b Power supply. Circuit diagram. Module M3364

Fig. 5a Power supply. Component layout. Module M3364

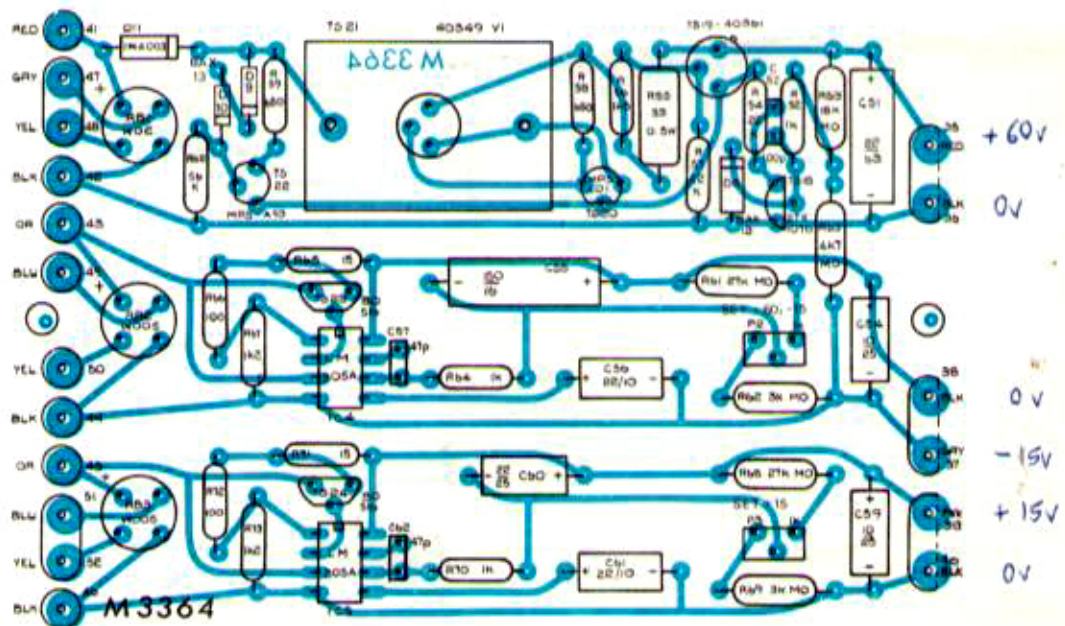

Fig. 6a Transformer amplifier. Component layout. Module M3370

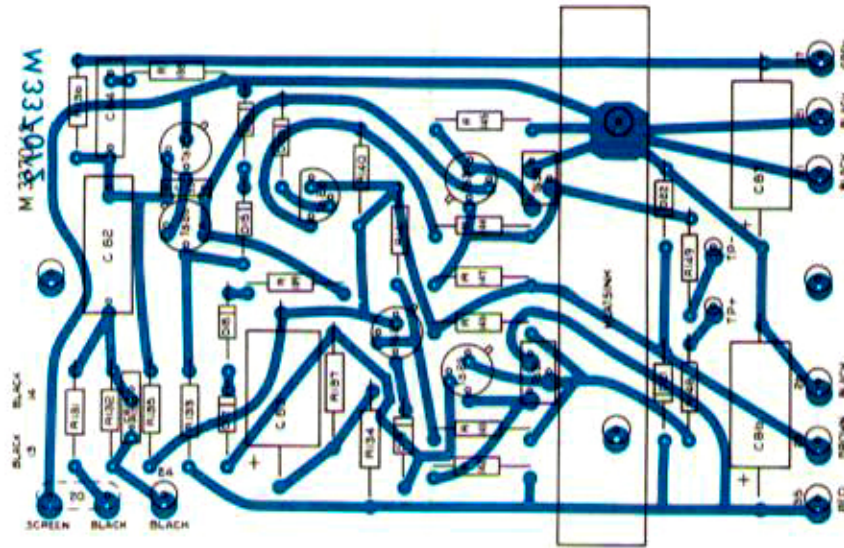

Fig. 6b Transformer amplifier. Circuit diagram. Module M3370

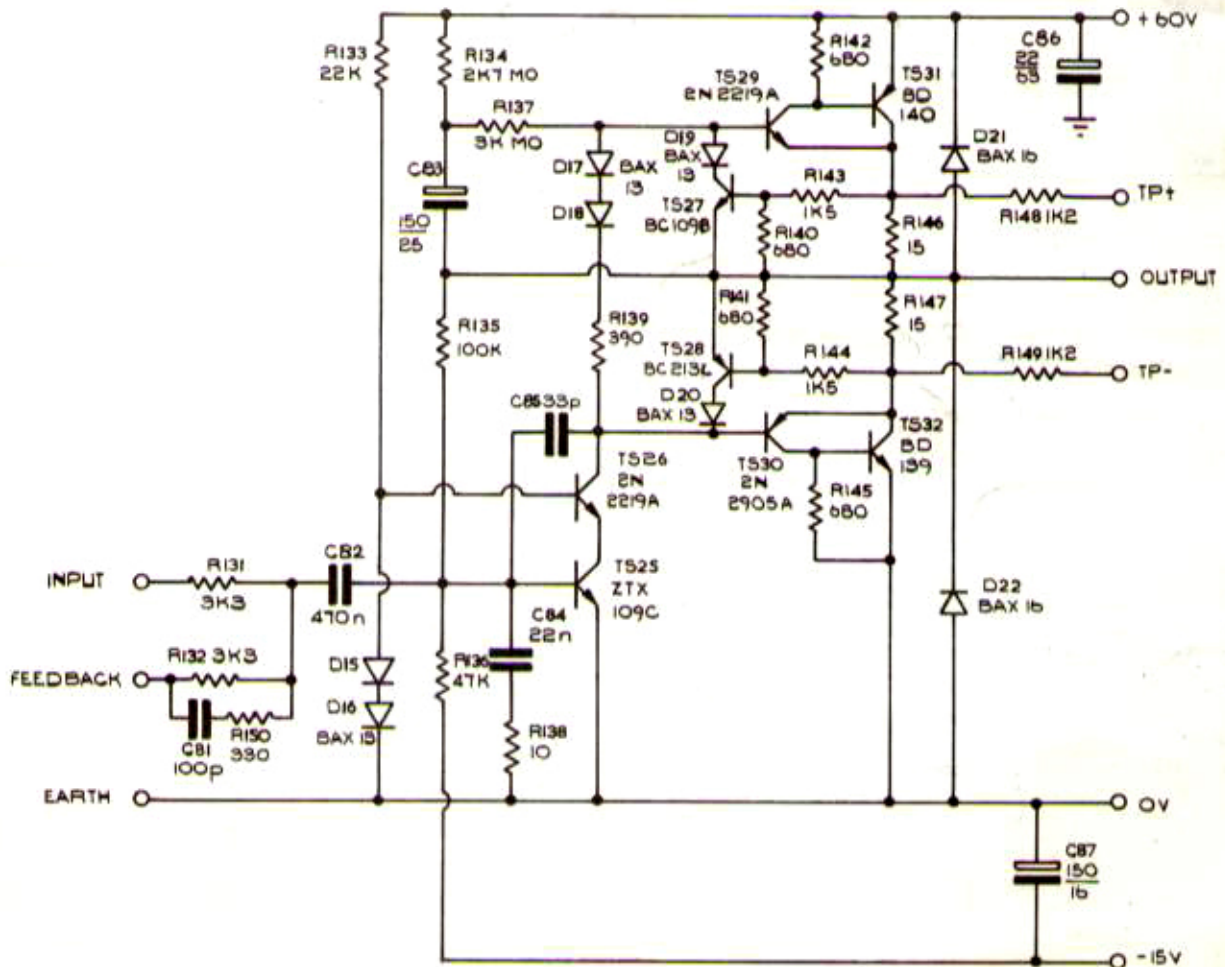
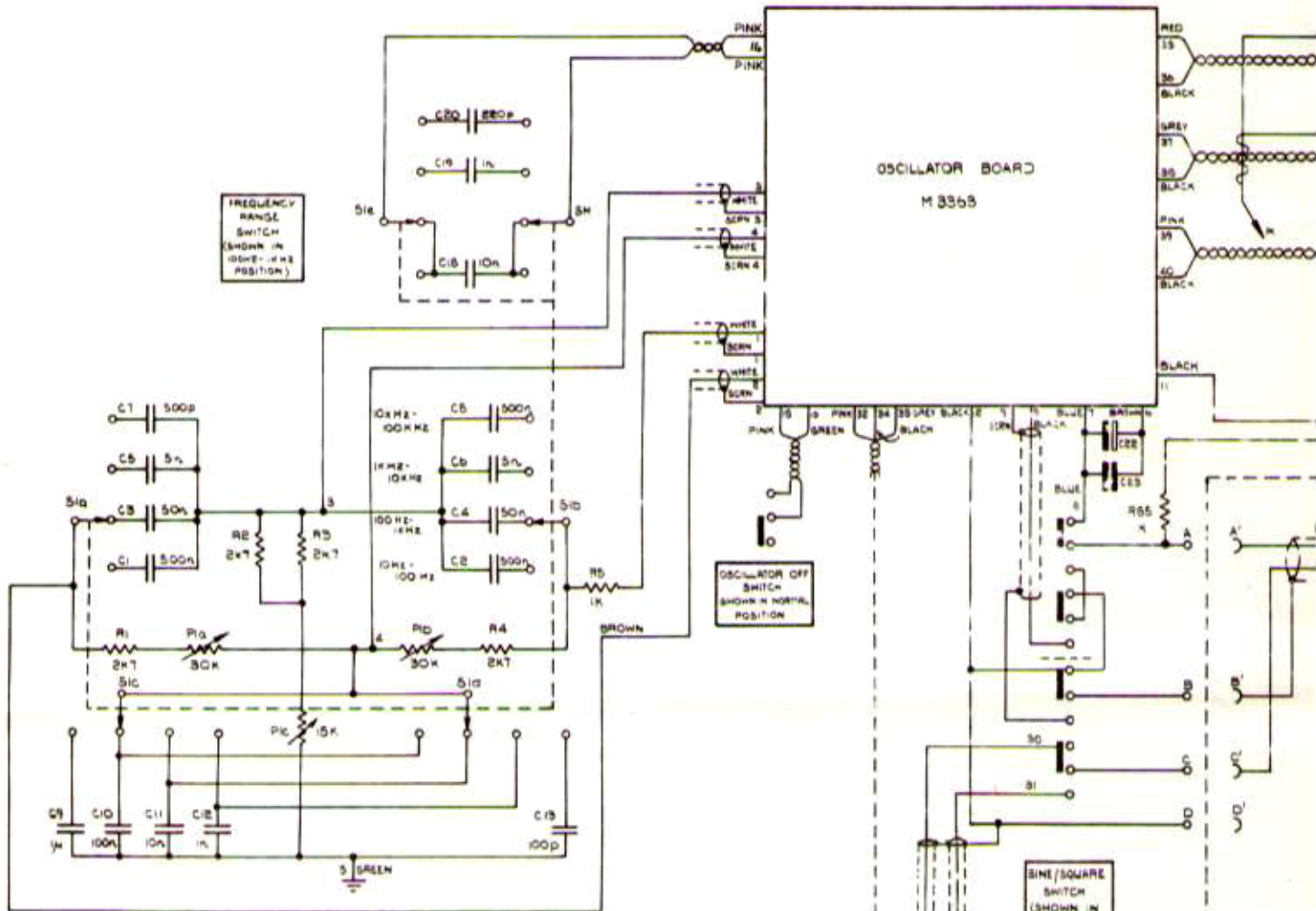

Fig. 1 Schematic diagram



LOW DISTORTION OSCILLATOR

SERIES 3.

SCHEMATIC LAYOUT

- 1 STANDARD MODEL L D O 3 (150 OMS UNBALANCED OUTPUT)
- 2 BALANCED OUTPUT MODEL L D O 3B.

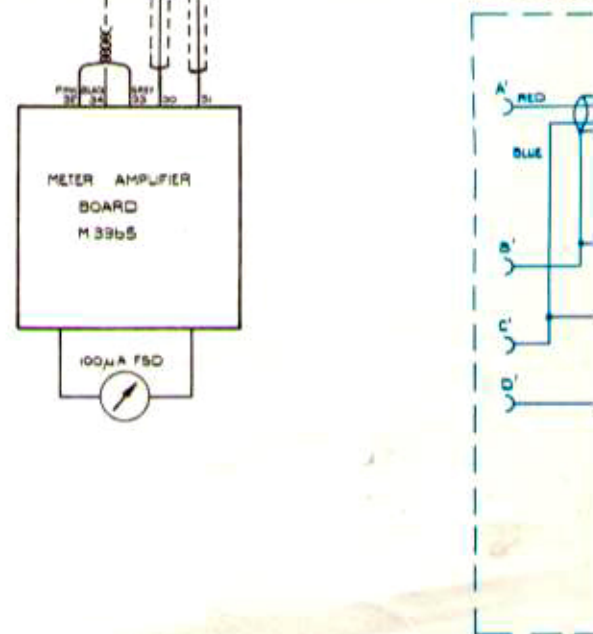

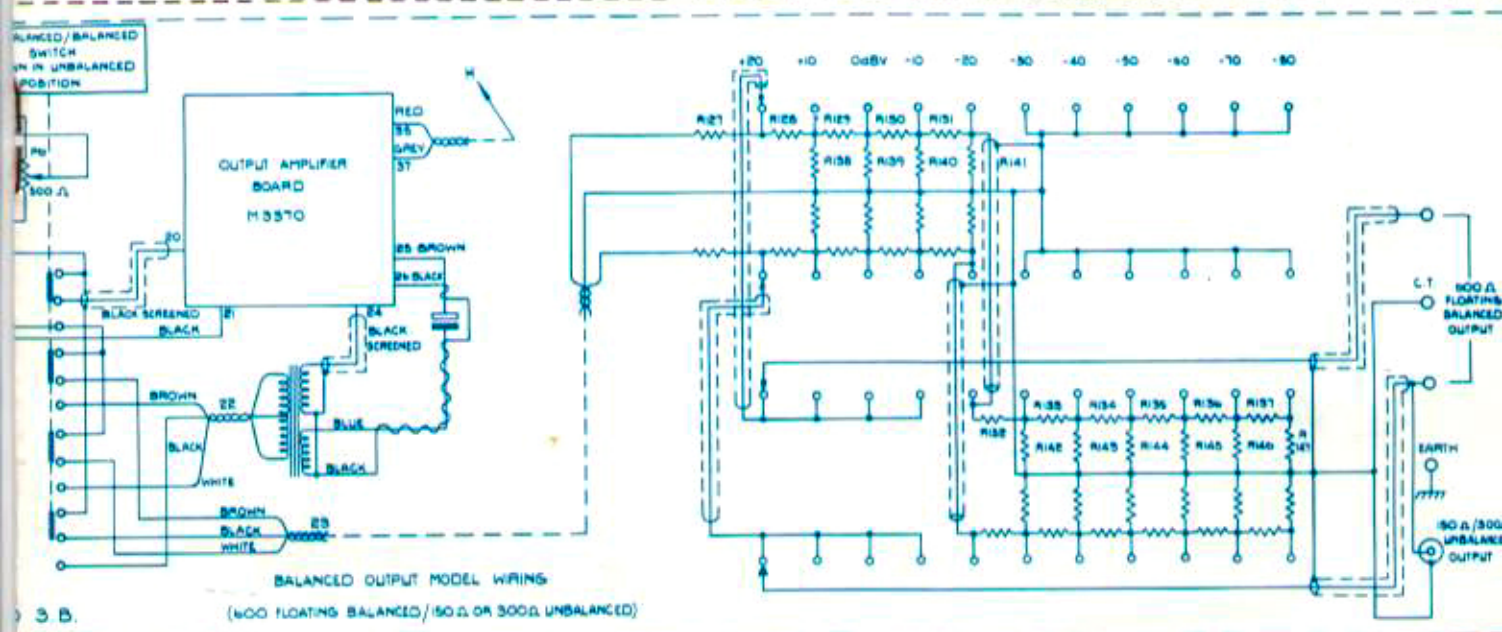
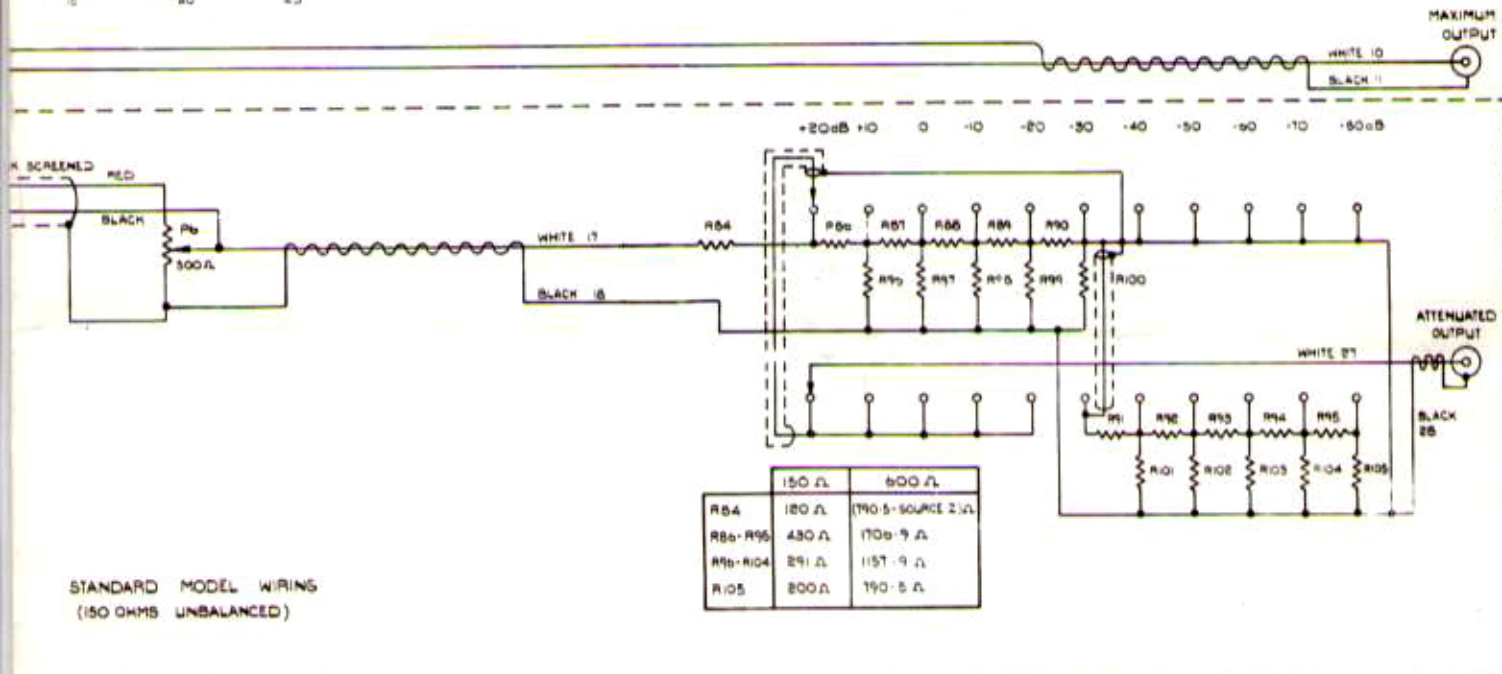
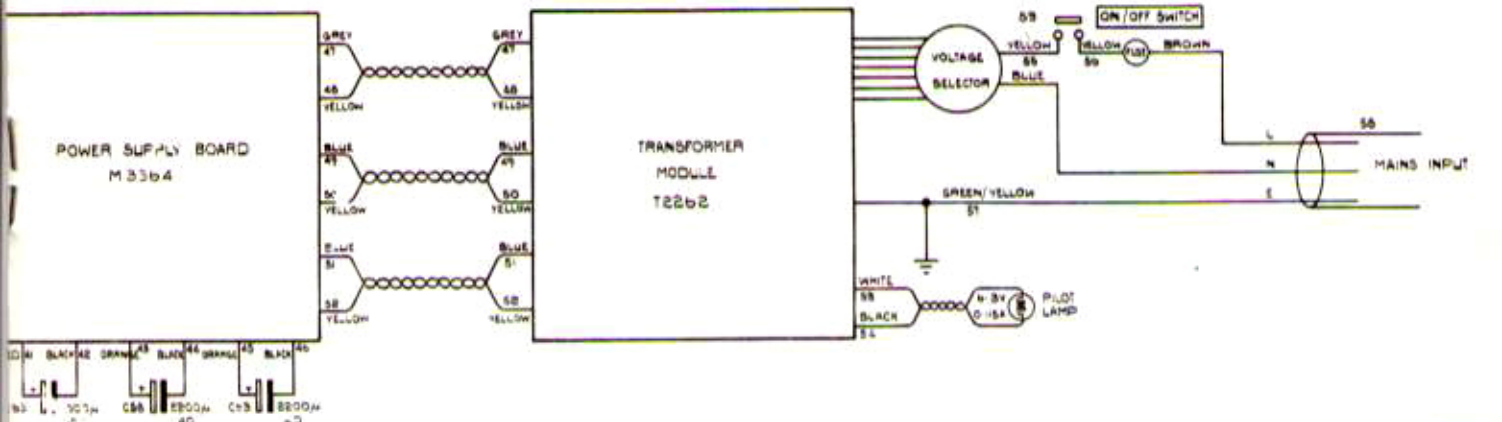

Fig. 7a Oscillator amplifier and limiter.
Component layout. Module M3363/2

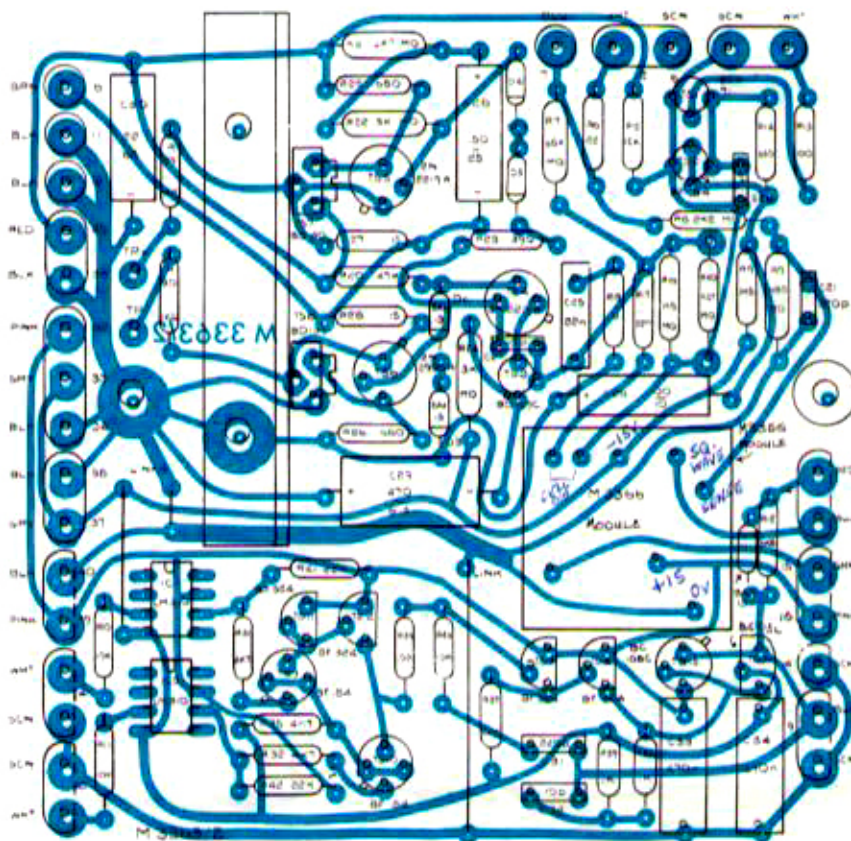

Fig. 7b Oscillator amplifier and limiter.
Component layout. Module M3363/4

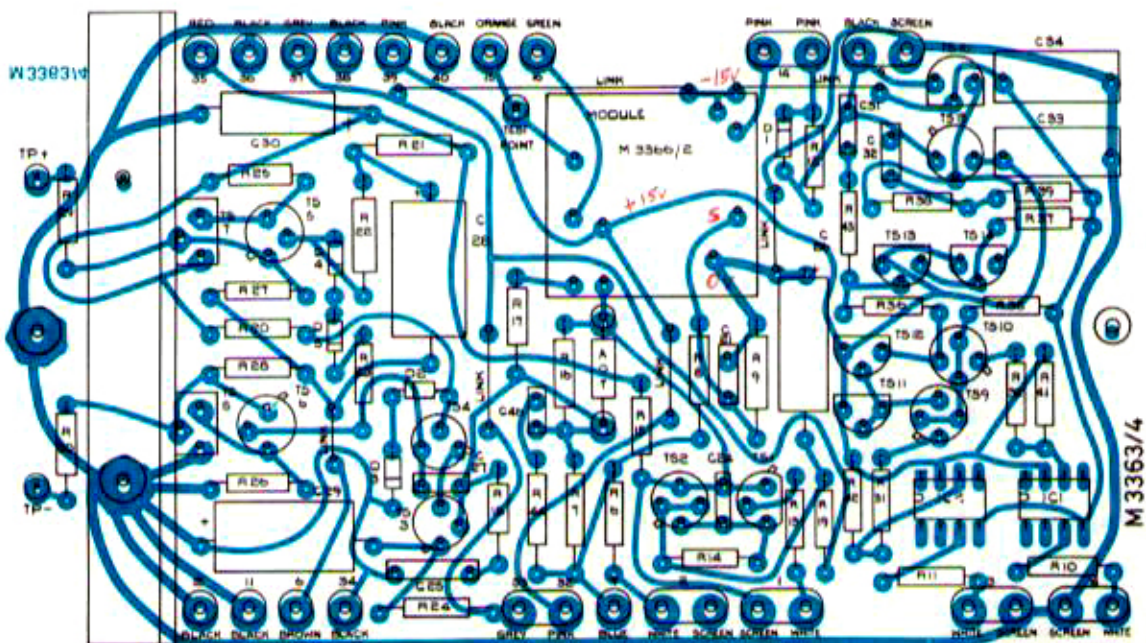

Fig. 7c Oscillator amplifier. Circuit diagram.
Module M3363

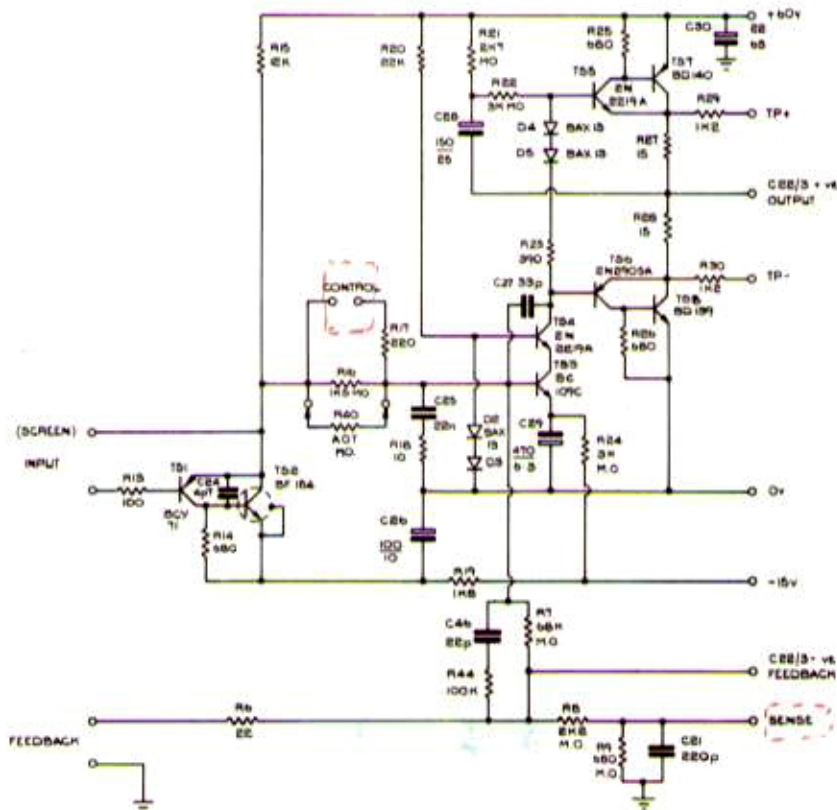

Fig. 7d Limiter. Circuit diagram.
Module M3363

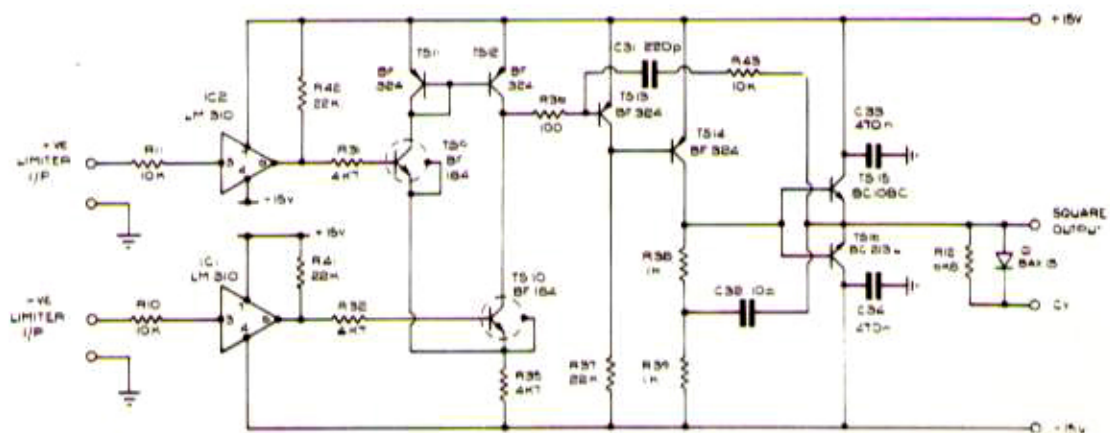

Fig. 8a Meter amplifier. Component layout
Module M3365

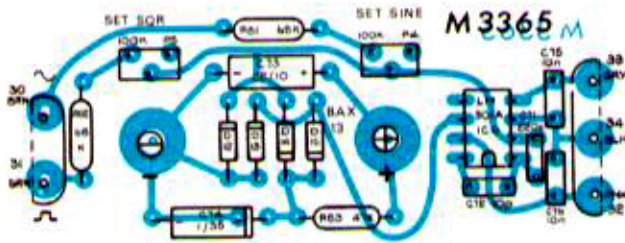
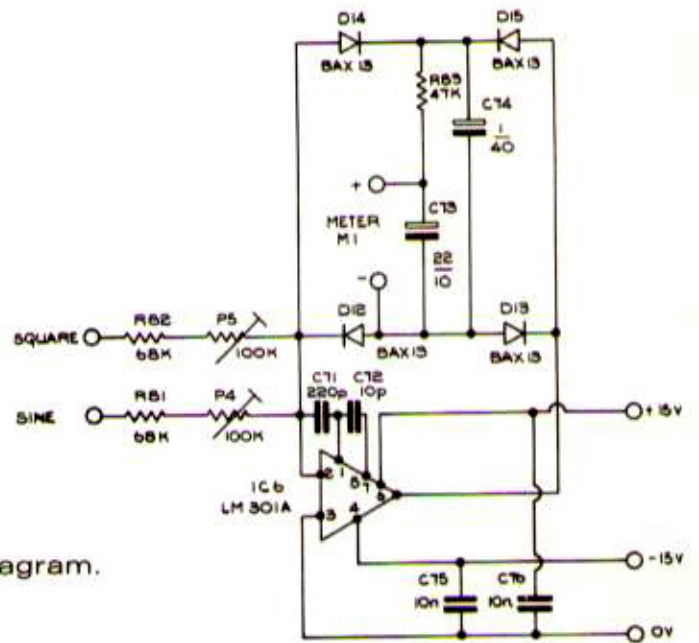

Fig. 8b Meter amplifier. Circuit diagram.
M3365



CONTROL CELL :

YOKOHAMA, JAPAN (MORIAICA)
MCD-521 (7K)



[670 μ
normal
operation?]

Low Distortion Oscillator LDO3.B. Balanced output model

1. General

The Low Distortion Oscillator LDO3.B is a standard LDO3 additionally fitted with an output transformer to provide a floating (isolated) output of 600 ohms source resistance balanced about a centre tap. The three output terminations are connected to press type terminals, any of which may be connected to an adjacent terminal at earth (chassis) potential. By suitable external connections the following output arrangements may be obtained.

1. **600 ohms.** Floating; balanced to centre tap, floating or earthy; unbalanced.
2. **300 ohms.** Floating; unbalanced.
3. **150 ohms.** Unbalanced.

The diagram, Fig. 9, shows the wiring from the attenuator to the terminals and illustrates the various output connections. The unbalanced output (BNC) socket must be left unconnected when using balanced output.

2. Performance characteristics, 600 ohms output

2.1 Distortion

Typical distortion characteristics against frequency are shown in Fig. 10.

2.2 Frequency response

Typical frequency response characteristics are shown in Fig. 11.

2.3 Balance

Typical balance figures for the 600 ohm output are:

1kHz - 80dB, 10kHz - 60dB

The method of measurement is shown in Fig. 12.

3. Overall schematic of LDO3.B

In the LDO3.B the 150 ohm standard model output wiring (shown in the black dotted rectangle, Fig. 1) is replaced by the 600 ohm output wiring (shown in the blue dotted rectangle, Fig.1.)

Fig. 9 Output schematic

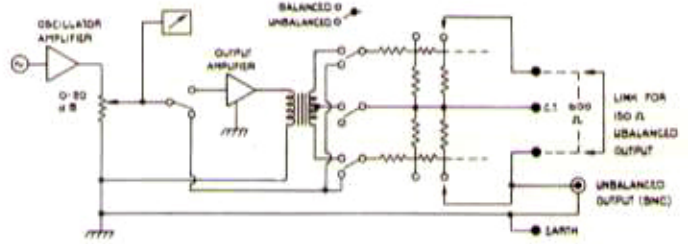

Fig. 12 Output balance test.

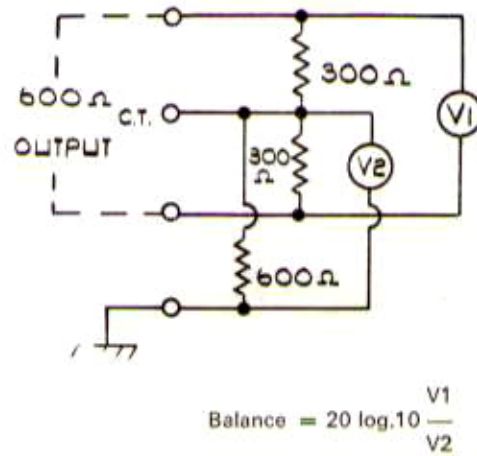

Fig. 10 Typical distortion characteristic LDO3.B.

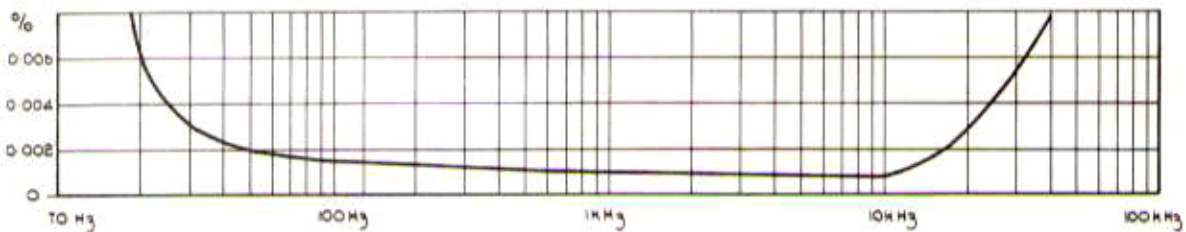
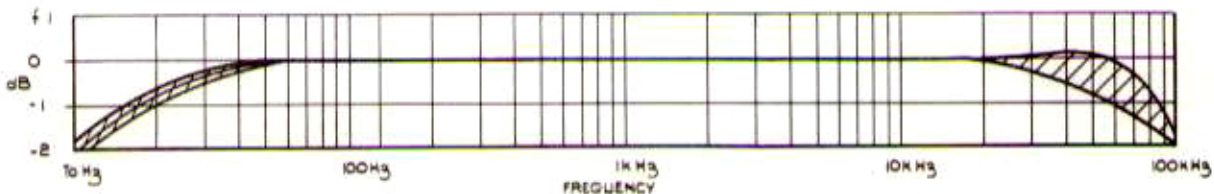

Fig. 11 Typical frequency response characteristic LDO3.B.



Component: 2N2219A transistor. Circuit reference TS4

This is the main contributor to distortion in the oscillator. Some manufacturers' transistors are better than others and vary from batch to batch. It should be noted that some makes of 2N2219A are unsuitable because of squegging when the oscillator is tuned to frequencies above 60 kHz, although they satisfy the condition of low distortion below the squegging frequency.

Component: BC109C transistor, circuit reference TS3

Distortion may also be introduced by this transistor but the incidence is small compared with TS4.

Components: 0.47 μ F and 0.047 μ F. Circuit reference C1 and C3

Capacitors C₁, C₂, C₃ and C₇ in the feedback circuit from the oscillator amplifier have a higher voltage applied to them than components in the other branches of the twin T circuit. A non-linearity in the voltage/current relationship in the capacitor will produce distortion. In practice it has exhibited itself on the two low frequency bands controlled by C₁ and C₂. 100 V rated capacitors have a considerably higher yield than 63 V capacitors for low distortion, although the applied voltage is approximately 12 V r.m.s.

Component: 500 ohm potentiometer. Circuit reference P6

Initially cermet potentiometers were used in this position, subsequently replaced by a moulded track type, and now wire wound.

Distortion is introduced by non-linearity of the contact resistance between the slider and the resistance element. It can occur in cermet, moulded carbon and wirewound controls but less frequent in wirewound types. It can be corrected in W.W. types by adjustment to provide a lower contact resistance between slider and element. The fault exhibits itself in a higher distortion reading when P6 (0-20 dB attenuator) is adjusted to approximately 20% of maximum of output, than when set for maximum output. If cleaning the wiper and track with a solvent and increasing the contact pressure does not eliminate the distortion it should be replaced.

Should you require advice or the supply of any component, module or sub assembly please write to the Service Department, Hedley Radford Instruments Bristol BS3 2HZ, England, or in the case of countries outside the U.K. to the Radford agent/importer.

5. GUARANTEE

Home

This instrument is guaranteed for a period of one year from the date of purchase. It covers the free replacement or repair of any defective component or part of the equipment during this period. It also covers the cost of labour in executing the repair or replacement if the instrument is returned to the factory service department, carriage paid, within the guarantee period.

Overseas

It is generally not practicable to return the instrument to the factory in England and instruments will normally be maintained in a serviceable condition by the replacement of sub-assemblies, modules or specific component parts.

In the case of instruments purchased through an Agent in a country outside the U.K., the agent will act for the manufacturer in that country. Service enquiries should therefore be directed to the Agent.

If the instrument is purchased direct from the factory in countries where there is no Radford Agent, enquiries should be directed to the Service Department in Bristol.

Diagrams

- Fig. 1 Schematic diagram
- Fig. 2 Layout. Original design. Plan view
- Fig. 2b Layout. Modified design. Plan view
- Fig. 3a Layout. Underside
- Fig. 3b Layout. Underside (Floating output model)
- Fig. 4 Layout. Rear panel inside view
- Fig. 5a Power supply. Component layout. Module M3364
- Fig. 5b Power supply. Circuit diagram. Module M3364
- Fig. 6a Transformer amplifier. Component layout. Module M3370
- Fig. 6b Transformer amplifier. Circuit diagram. Module M3370
- Fig. 7a Oscillator amplifier and limiter. Component layout. Module M3363/2
- Fig. 7b Oscillator amplifier and limiter. Component layout. Module M3363/4
- Fig. 7c Oscillator amplifier. Circuit diagram. Module M3363/4
- Fig. 7d Limiter. Circuit diagram. Module M3363/4
- Fig. 8a Meter amplifier. Component layout. Module M3365
- Fig. 8b Meter amplifier. Circuit diagram. M3365
- Fig. 9 Output schematic
- Fig. 10 Typical distortion characteristic LDO3.B.
- Fig. 11 Typical frequency response characteristic LDO3.B.
- Fig. 12 Output balance test.